

X-Future Handguard

Paramano X-Future

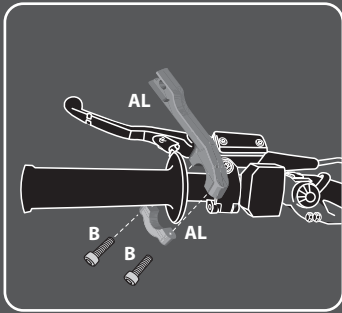
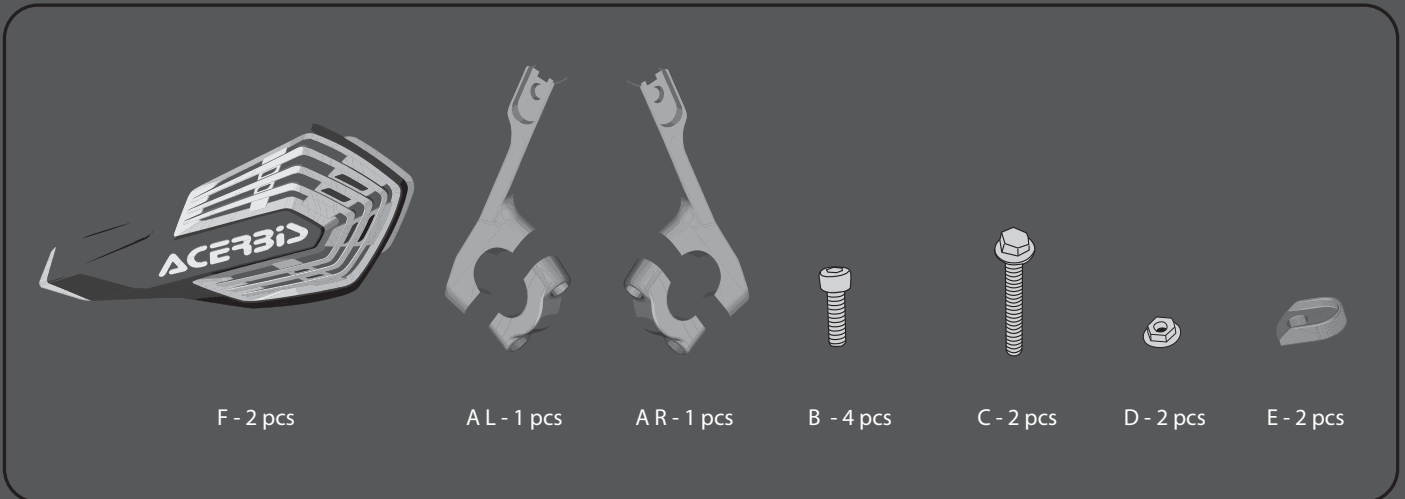

1- Attach the Left side mount (AL) to the handlebar using the screws (B).

1- Assemblare il bracciale sinistro (AL) al manubrio attraverso le viti (B).

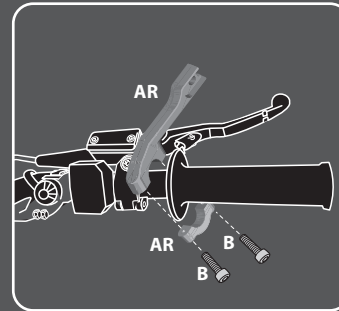

1- Repeat the process with the Right side mount (AR). The mounts should extend over the top of the levers.

1- Ripetere il processo con il bracciale destro (AR).

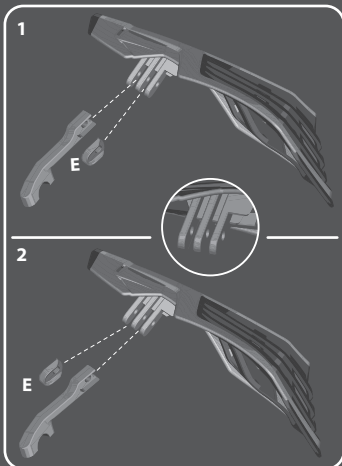

2- Depending on your mounting location on the bars, attach the shields to the mounts utilizing the internal or external mounting points.

2- Scegliere dove posizionare il paramano:
posizione 1 - paramano più esterno
posizione 2 - paramano più interno
Inserire il tassello (E) nello spazio rimasto libero.

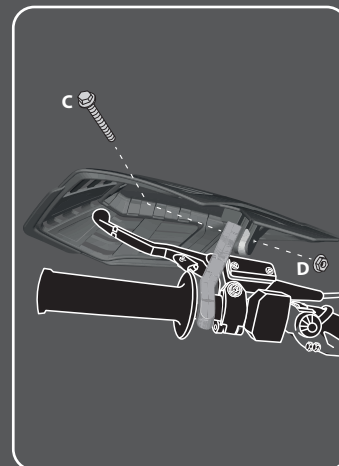

3- Insert and tighten the screw C and the nut (D) to attach the shields to the mount. Check the bolts (B) on the mount to ensure they are also tight.

3- Fissare il paramano al bracciale attraverso vite (C) e dado (D). Controllare che le viti (B) siano completamente avvitate.

WARNING! Follow mounting instruction exactly. Ensure that the mounting is secure before riding.

These hand guards will not prevent injury in the event of a crash. They are designed to protect the hands from cold weather and impact with small branches you might hit and flying debris. Be sure that you follow the instruction for anstalling the hand guards. Do not ride with a brocken tie wrap. Check to be sure the throttle and other controls are free every time you ride. Failure to heed instruction and this warning could lead to interference with the controls, loss of control of the motorcycle, and an accident.